

MECHANICAL SPECIFICATIONS

FIXTURE	PACKED IN ROADCASE
Dimensions:	Dimensions
mm: 594 x 690 x 950	mm: 711 x 737 x 1168
in: 23.4 x 24.8 x 38.4	in: 28 x 29 x 46

Weight: 63.5 kg (140 lbs) **Weight:** 118 kg (260 lbs)

Mounting Information: The DL.3 fixture can be truss mounted using the 1/4 turn camlock c-clamp mounting brackets provided. It can also stand upright on a stable surface.

Colors Available: Black:

ELECTRICAL/LAMP SPECIFICATIONS

Input ratings: 100–120V 7.0A maximum 50/60Hz,
200–240V 3.5A 50/60Hz

Power factor: 0.94

Fuse: Power supply output fuse: 5A, 250V slow blow only.

Lamp: 330W NSH

Light Output: 7000 ANSI lumens

Rated Lamp Life: 2000 hours

COMPUTER

Processor: Intel Core i7-3770

Memory: 4 GB DDR3 RAM

Hard drive: 1 TB Western Digital SATA

Video Card: AMD Radeon HD5770:

SDI Capture Card: BlackMagic Decklink SDI HD

SVideo Capture Card: Hauppauge WinTV 1600

Operating System: Windows XP embedded

PROJECTOR

Model: Sanyo PLC-XP200L

Aspect ratio: 4:3 native

Brightness uniformity: 90%

Contrast ratio: 2000:1 full on/full off

Vertical Lens Shift: 107%

CAMERA SYSTEM

Construction: Super HAD CCD sensor technology

Lens: 18x Optical Zoom

Horizontal view angle: 48° – 2.8°

Auto focus Range: 29mm – 800mm

Display technology: 1.3" TFT Poly-S: x3/Color Control x1

Panel resolution: 1024 x 768

Standard Zoom Lens Throw Ratio: 1.8 - 2.4:1

Accessory Long Zoom Lens Throw Ratio: 2.4-4.3:1

Accessory Ultra Long Zoom Lens Throw Ratio: 4.3-6.0:1

Accessory Wide Angle Zoom Lens Throw Ratio: 1.3-1.8:1

OPERATION

Movement Accuracy: Pan and Tilt from the same direction to the programmed point within approximately .01°.

Control Options: DMX512, Art-Net

Minimum Focus Distance: 1.4 meters (4.6 ft)

Compliances: CE, CSA, ETL

Video Connectors: RGBHV—BNC x 5, VGA—DB15, S-Video—mini-DIN, SDI input/output

Camera Capture Resolution: 768 x 494 pixels

Picture Elements: 380K pixels {768 (H) x 582 (V)}

Minimum working distance: 29mm (TELE end, 800mm (WIDE end)

DMX Connectors: 5-pin male and female XLR connectors

Scanning Frequency: H-sync. = 15 – 100 KHz, V-sync. = 50 – 100 Hz

Horizontal Resolution: 800 TV lines (HDTV)

Environmental Tolerances:

Ambient Operating Temperature Range: 5°–40°C (40°–104° F)

Humidity: 20%–80% (non-condensing)

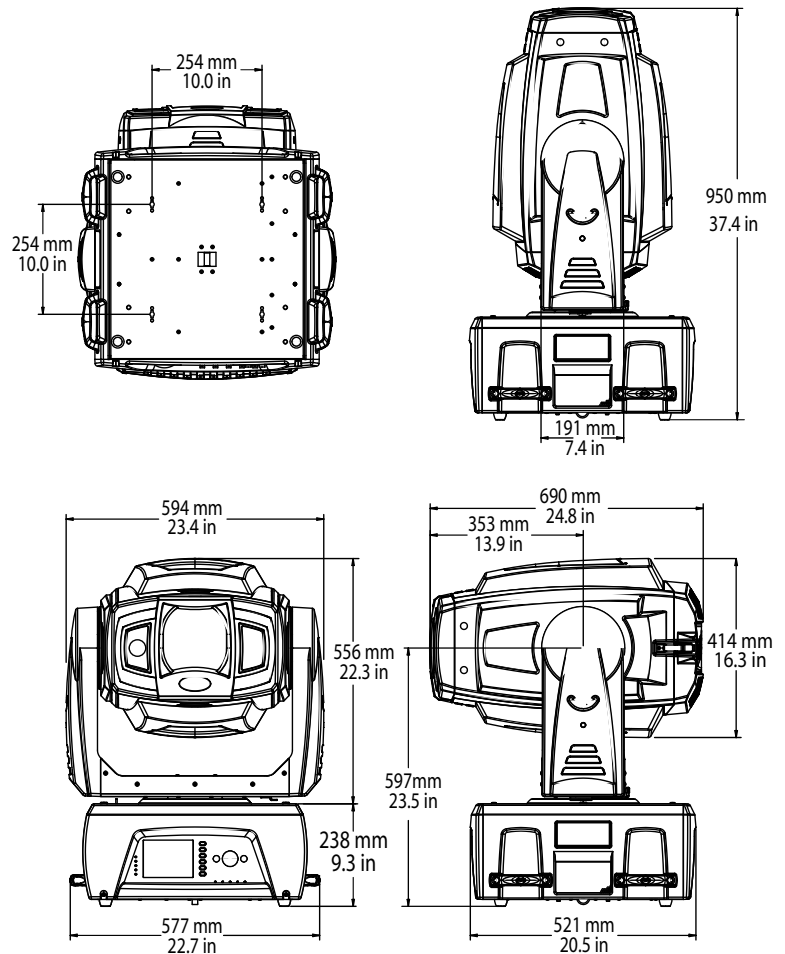

DMX Channels (Version 2 Protocol)

Motion Parameters	DMX Chan	Global Parameters	DMX Chan	Graphic Object Parameters	DMX Chan								
					Obj.1	Obj.2	Obj.3	Obj.4	Obj.5	Obj.6	Obj.7	Obj.8	Obj.9
Motion Functions		Global Intensity	22	Opacity	77	122	167	212	257	302	347	392	437
Pan	1	Global Effect 1	23	3-D Object File	78	123	168	213	258	303	348	393	438
	2	Global Effect 1 Modifier 1	24	Media Folder	79	124	169	214	259	304	349	394	439
Tilt	3	Global Effect 1 Modifier 2	25	Media file	80	125	170	215	260	305	350	395	440
	4	Global Effect 1 Modifier 3	26	In frame	81	126	171	216	261	306	351	396	441
Dimmer	5	Global Effect 2	27		82	127	172	217	262	307	352	397	442
Focus	6	Global Effect 2 Modifier 1	28	Out frame	83	128	173	218	263	308	353	398	443
Zoom	7	Global Effect 2 Modifier 2	29		84	129	174	219	264	309	354	399	444
Mspeed	8	Global Effect 2 Modifier 3	30	Play mode	85	130	175	220	265	310	355	400	445
Macro	9	Global Effect 3	31	Play speed	86	131	176	221	266	311	356	401	446
Control	10	Global Effect 3 Modifier 1	32	Sync Mode	87	132	177	222	267	312	357	402	447
Camera Functions		Global Effect 3 Modifier 2	33	Sync To	88	133	178	223	268	313	358	403	448
Zoom	11	Global Effect 3 Modifier 3	34	Visual mode	89	134	179	224	269	314	359	404	449
	12	Global Effect 4	35	Visual Mode Modifier 1	90	135	180	225	270	315	360	405	450
Focus	13	Global Effect 4 Modifier 1	36	Visual Mode Modifier 2	91	136	181	226	271	316	361	406	451
	14	Global Effect 4 Modifier 2	37	Graphic Effect 1	92	137	182	227	272	317	362	407	452
Infrared	15	Global Effect 4 Modifier 3	38	Effect 1 Modifier 1	93	138	183	228	273	318	363	408	453
Camera Shutter	16	Global Effect 5	39	Effect 1 Modifier 2	94	139	184	229	274	319	364	409	454
White Balance	17	Global Effect 5 Modifier 1	40	Effect 1 Modifier 3	95	140	185	230	275	320	365	410	455
Camera Orientation	18	Global Effect 5 Modifier 2	41	Graphic Effect 2	96	141	186	231	276	321	366	411	456
Camera Effects	19	Global Effect 5 Modifier 3	42	Effect 2 Modifier 1	97	142	187	232	277	322	367	412	457
Red Gain	20	Mask Select (default iris)	43	Effect 2 Modifier 2	98	143	188	233	278	323	368	413	458
Blue Gain	21	Mask Size	44	Effect 2 Modifier 3	99	144	189	234	279	324	369	414	459
		Mask Edge	45	Graphic Effect 3	100	145	190	235	280	325	370	415	460
		Edge Fade Top	46	Effect 3 Modifier 1	101	146	191	236	281	326	371	416	461
		Edge Fade Right	47	Effect 3 Modifier 2	102	147	192	237	282	327	372	417	462
		Edge Fade Bottom	48	Effect 3 Modifier 3	103	148	193	238	283	328	373	418	463
		Edge Fade Left	49		104	149	194	239	284	329	374	419	464
		Keystone Top Left X	50	X-axis rotation	105	150	195	240	285	330	375	420	465
		Keystone Top Left Y	51		106	151	196	241	286	331	376	421	466
		Keystone Top Right X	52	Y -axis rotation	107	152	197	242	287	332	377	422	467
		Keystone Top Right Y	53		108	153	198	243	288	333	378	423	468
		Keystone Bottom Right X	54	Z-axis rotation	109	154	199	244	289	334	379	424	469
		Keystone Bottom Right Y	55		110	155	200	245	290	335	380	425	470
		Keystone Bottom Left X	56	Scale X	111	156	201	246	291	336	381	426	471
		Keystone Bottom Left Y	57		112	157	202	247	292	337	382	427	472
		Keystone X Ratio	58	Scale Y	113	158	203	248	293	338	383	428	473
		Keystone Y Ratio	59		114	159	204	249	294	339	384	429	474
		Framing Top Left X	60	Scale Z	115	160	205	250	295	340	385	430	475
		Framing Top Left Y	61		116	161	206	251	296	341	386	431	476
		Framing Top Right X	61	X Position	117	162	207	252	297	342	387	432	477
		Framing Top Right Y	63		118	163	208	253	298	343	388	433	478
		Framing Bottom Right X	64	Y Position	119	164	209	254	299	344	389	434	479
		Framing Bottom Right Y	65		120	165	210	255	300	345	390	435	480
		Framing Bottom Left X	66	Z Position	121	166	211	256	301	346	391	436	481
		Framing Bottom Left Y	67										
		Viewpoint mode	68										
		Viewpoint Position X	69										
			70										
		Viewpoint Position Y	71										
			72										
		Viewpoint Position Z	73										
			74										
		Global Control	75										
		Global Control Modifier	76										

PART NUMBERS

Fixture

68010001: DL3 fixture, Black

Accessories

55030085EF: XP100 Replacement Lamp

V131276: XP200 Replacement Lamp

67060002: Long Zoom Lens kit

67060001: Ultra Long Zoom Lens kit

68060003: Wide Angle Zoom Lens kit



HIGH END SYSTEMS

High End Systems

2105 Gracy Farms Lane
Austin, TX 89858 USA

voice: 512.836.2242

fax: 512.837.5290

Toll Free: 800.890.8989

Customer Service

2105 Gracy Farms Lane
Austin, TX 89858 USA

voice: 800.890.8989

fax: 512.834.9195

Toll free: 800.890.8989